

8	contamination indicator	
7	Suction port	R2"
6	Suction port	R3"
5	Oil drain plug	
4	Leakage oil-	Pump
3	Breather cartridge	
2	Leakage oil-	Crane
1	Return oil filter	

Tank volume	200 l
Weight	70.4 kg
Return oil filter	350 l/min
Breather cartridge	800 l/min
Work material	Steel
wall thickness	3 mm

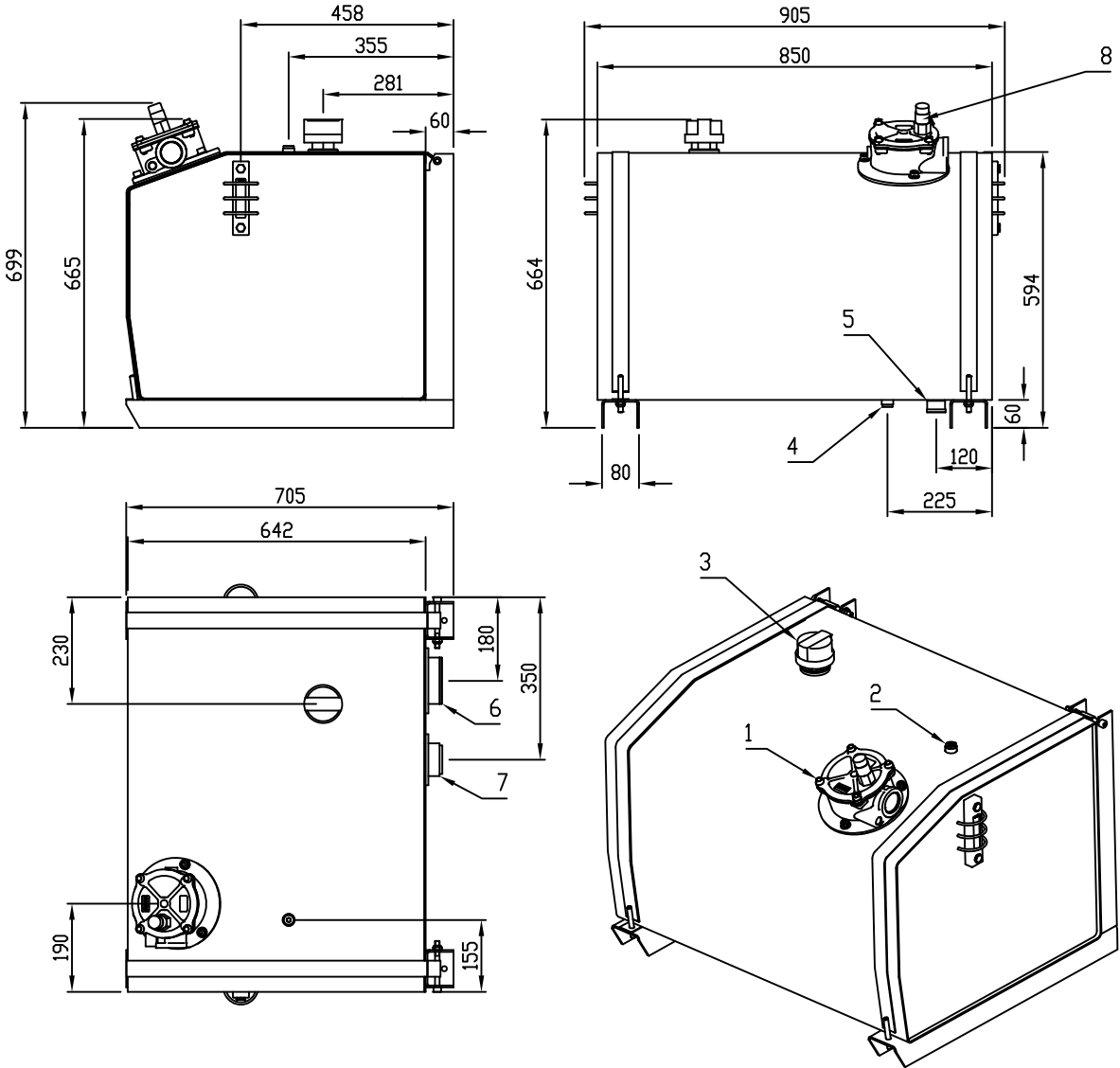

8	contamination indicator	
7	Suction port	R2"
6	Suction port	R3"
5	Oil drain plug	
4	Leakage oil-	Pump
3	Breather cartridge	
2	Leakage oil-	Crane
1	Return oil filter	

Tank volume	250 l
Weight	78.6 kg
Return oil filter	350 l/min
Breather cartridge	800 l/min
Work material	Steel
wall thickness	3 mm

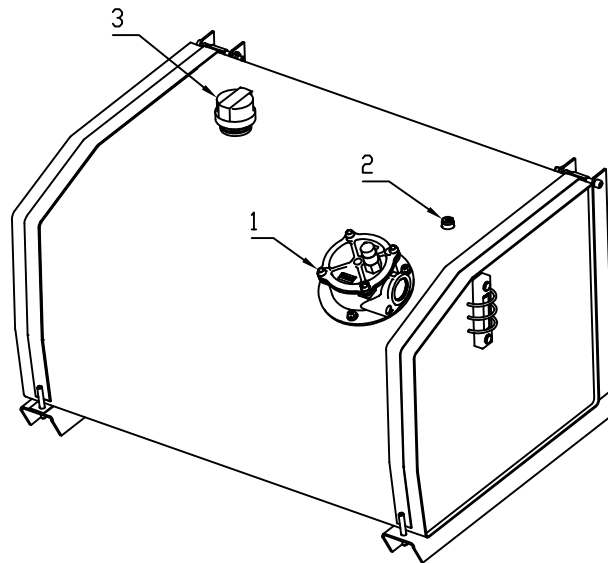
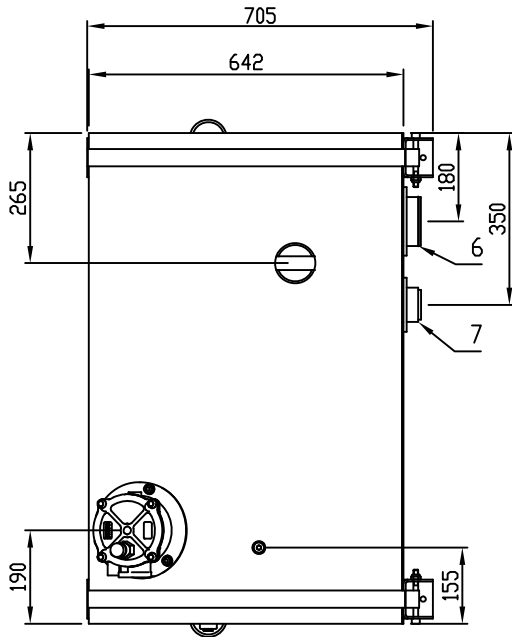
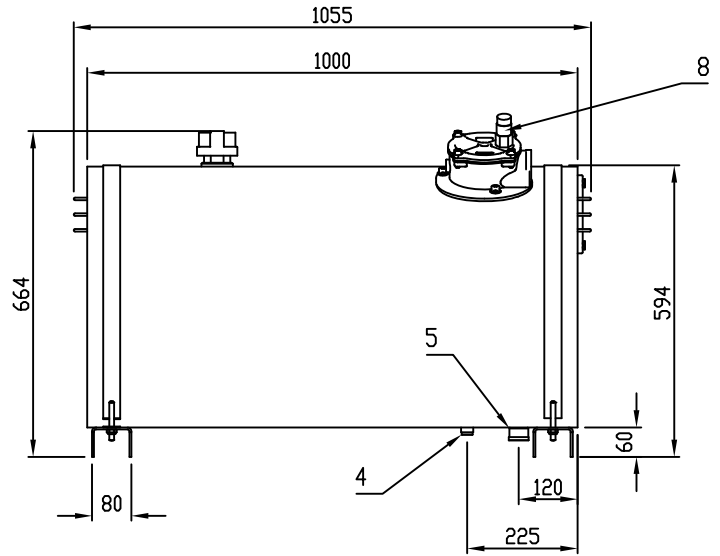
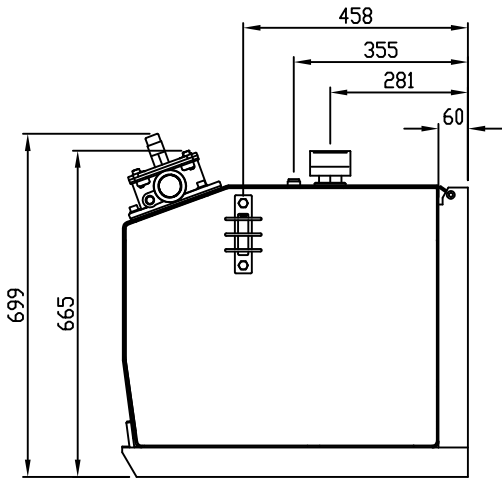

8	contamination indicator	
7	Suction port	R2"
6	Suction port	R3"
5	Oil drain plug	
4	Leakage oil-	Pump
3	Breather cartridge	
2	Leakage oil-	Crane
1	Return oil filter	

Tank volume	300 l
Weight	86.5 kg
Return oil filter	350 l/min
Breather cartridge	800 l/min
Work material	Steel
wall thickness	3 mm

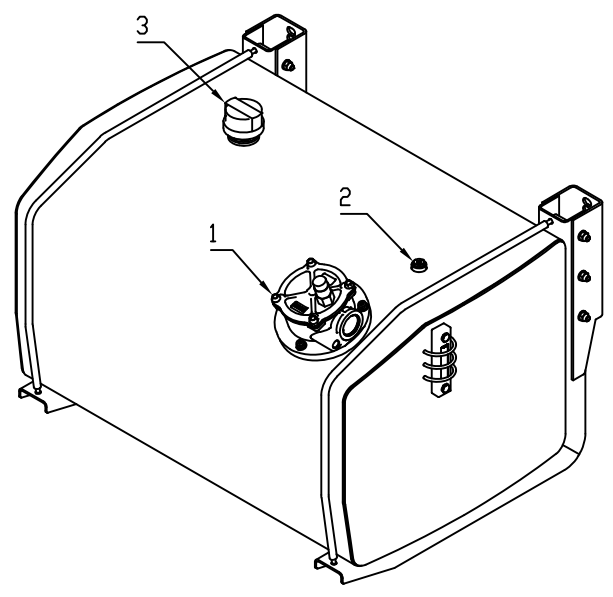
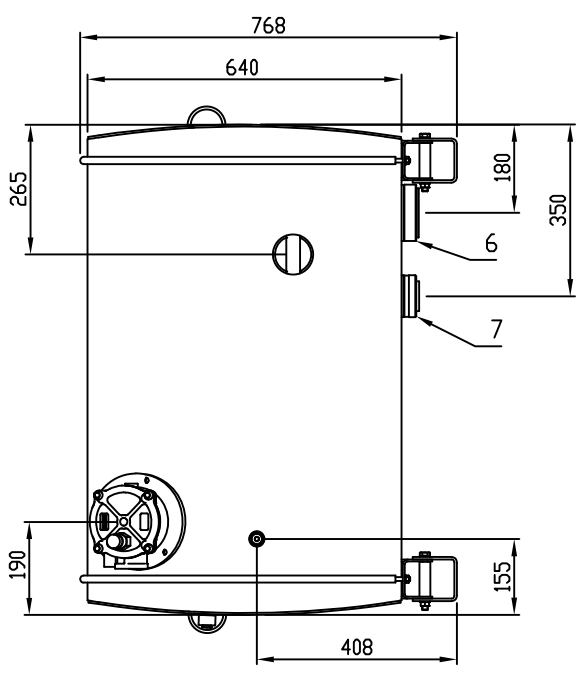
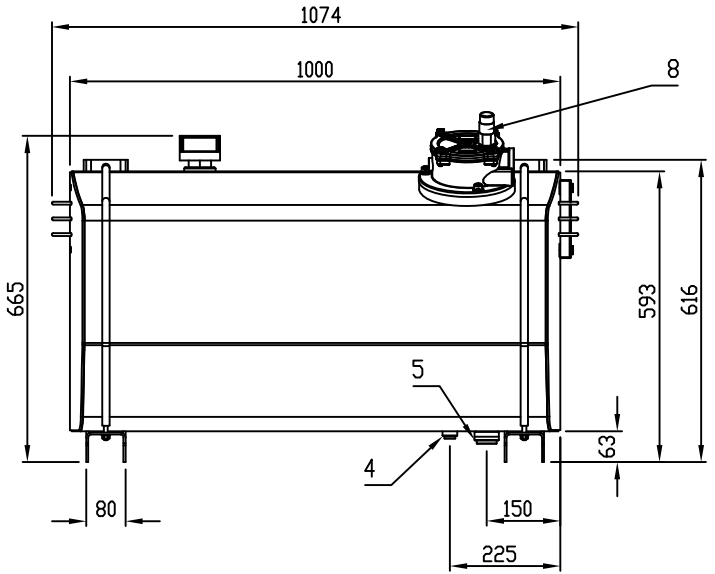
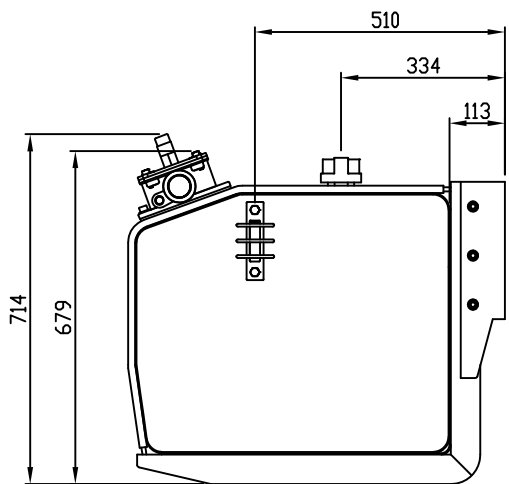

8	contamination indicator	
7	Suction port	G2"
6	Suction port	G3"
5	Oil drain plug	
4	Leakage oil-	Pump
3	Breather cartridge	
2	Leakage oil-	Crane
1	Return oil filter	

Tank volume	300 l
Weight	34,90 kg
Return oil filter	350 l/min
Breather cartridge	800 l/min
Work material	(Aluminium)
wall thickness	4 mm

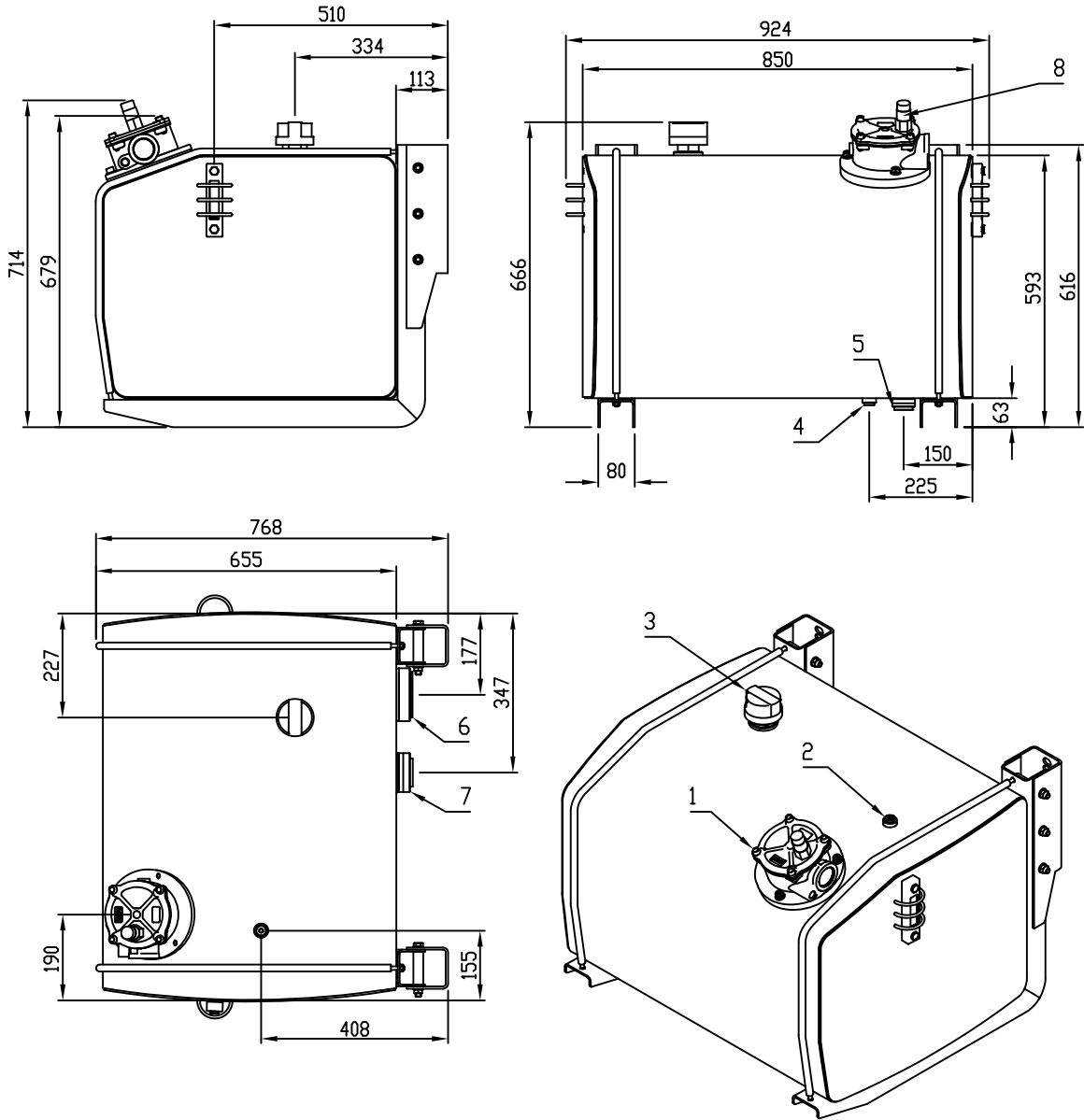

8	contamination indicator	
7	Suction port	G2"
6	Suction port	G3"
5	Oil drain plug	
4	Leakage oil-	Pump
3	Breather cartridge	
2	Leakage oil-	Crane
1	Return oil filter	

Tank volume	250 l
Weight	31.32 kg
Return oil filter	350 l/min
Breather cartridge	800 l/min
Work material	(Aluminium)
wall thickness	4 mm

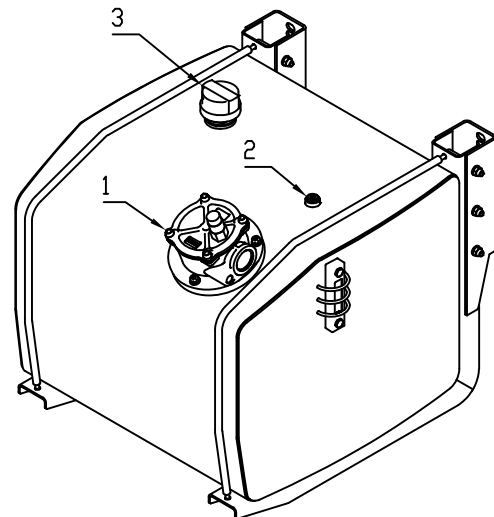
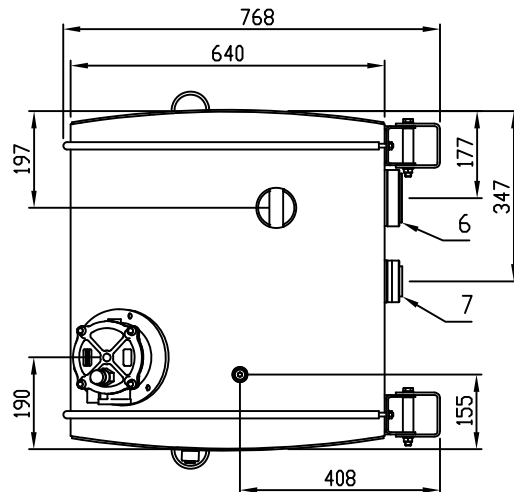
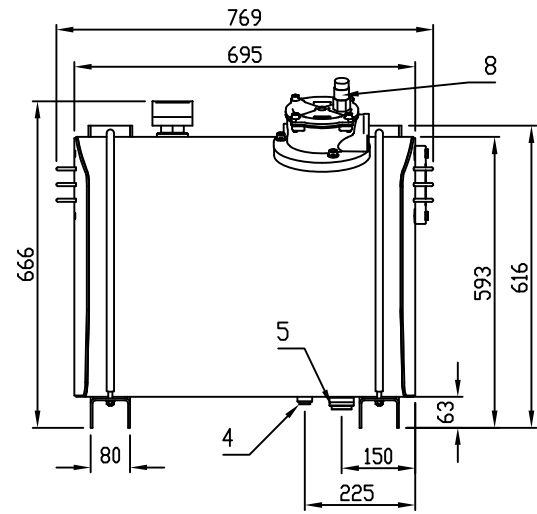
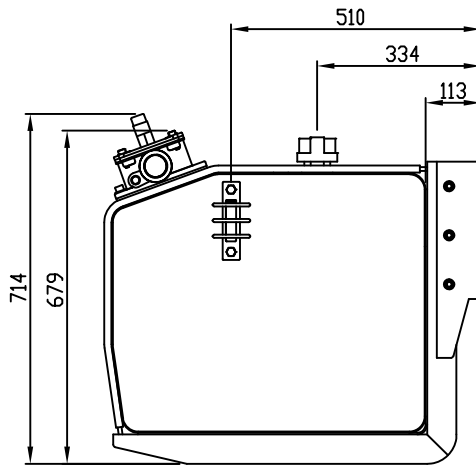

8	contamination indicator	
7	Suction port	G2"
6	Suction port	G3"
5	Oil drain plug	
4	Leakage oil-	Pump
3	Breather cartridge	
2	Leakage oil-	Crane
1	Return oil filter	

Tank volume	200 l
Weight	44.16 kg
Return oil filter	350 l/min
Breather cartridge	800 l/min
Work material	(Aluminium)
wall thickness	4 mm